

GENERAL INFO

CARAVAN & RV PORTABLE WATER FILTER SYSTEMS

Purified water for your camping adventures

A portable inline water filter designed to connect up easily to garden hose fittings which are readily available in most locations.

The Puretec CR20 filter incorporates carbon filtration with SilverPlus™ Antibacterial Technology to remove taste, odour, chemicals and inhibit bacterial growth leaving healthy, great tasting water even while you are on the go.

SPECIFICATIONS

Model:	CR20
Rating	1 micron
Dimension	W 65 mm x H 305 mm
Connection	1/2" Garden Hose
Min/Max Flow:	0 - 20 litres per minute
Min/Max Temp:	2 - 38°C
Min/Max Pressure:	200 - 860 kPa

Important Note: Use only genuine Puretec replacement cartridge.

FEATURES & BENEFITS

- Ideal for camper trailers, boats, caravans and motorhomes
- Reduces sediment, taste and odour, chemical and bacteria from drinking water
- Portable water filters ensuring water is safe no matter where you are
- Connects to standard garden hose fittings
- SilverPlus™ antibacterial filtration technology

ADDITIONAL INFORMATION

CONNECTS TO STANDARD GARDEN HOSE FITTINGS

The Puretec CR Series are high capacity, efficient filter systems designed to connect up easily to garden hose fittings which are readily available in most locations.

SilverPlus™ ANTIBACTERIAL FILTRATION TECHNOLOGY

The Puretec Caravan filters incorporate carbon filtration with Silver Plus Antibacterial Technology to remove taste, odour, chemicals and inhibit bacterial growth leaving healthy, great tasting water even while you are on the go.

CONNECTS TO STANDARD GARDEN HOSE FITTINGS

A portable water filter designed to connect quickly and easily to your caravan or motor home

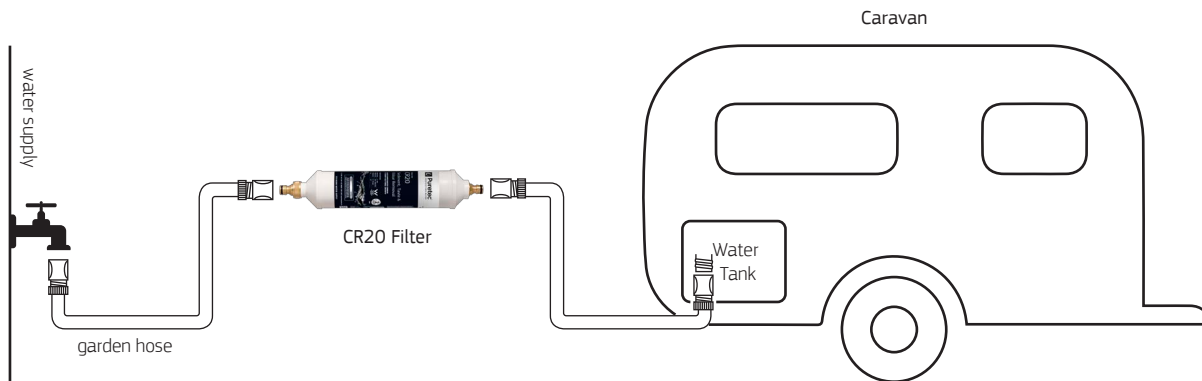

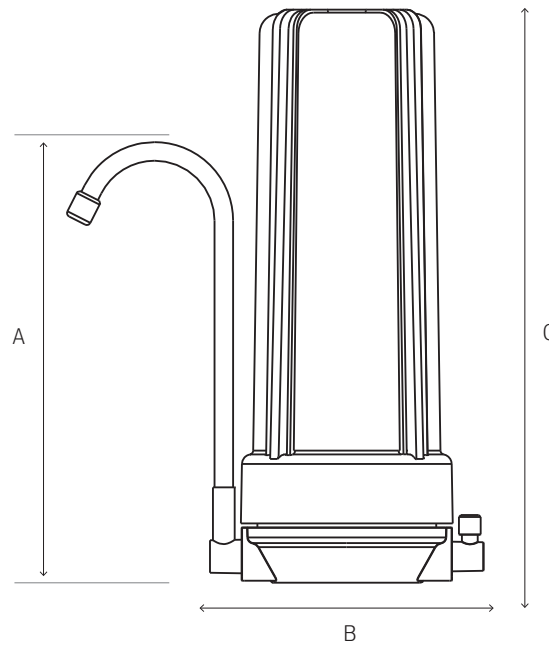

CT15

A	B	C
230 mm	152 mm	285 mm

GENERAL INFO

COUNTER-TOP WATER FILTER SYSTEM

The Puretec CT series is a portable water filter system for turning tap water into healthy delicious drinking water. Combined with its slimline design and portability, it offers a very convenient system for premium quality drinking water.

The Puretec CT series reduces chlorine, taste, odour, chemicals, and sediment leaving vital minerals for maintaining healthy life.

Enjoy your own clean, beautiful tasting water from this simple and effective system.

SPECIFICATIONS

Model	CT15
Min/Max Flow	0 - 4 litres per minute*
Min/Max Temperature	0 - 30°C (protect from freezing)
Min/Max Pressure	0 - 875 kPa
Connection	Connects to aerator thread
Warranty	3 years[^]

FEATURES & BENEFITS

- Convenient portability provided through flexible hose
- Quick and simple connection to tap for portability
- Valve diverts from unfiltered to filtered water
- Optional connection for taps without threads.
- Compact, durable, economical design

KIT INCLUDES

- Portable Counter Top Assembly
- Chrome Diverter Valve
- Cartridge [Installed]
- Thread Adapter
- User Guide

APPLICATIONS

- Kitchen: Cooking, drinking, beverages, replacement for inefficient filter jugs
- Caravan: Portable for camping trips
- Office: Replaces costly, inconvenient bottled water. An abundant supply of sparkling clear water at the touch of a tap
- Factory: Provides staff with safe and healthy water.

SPARE PARTS

Ordering Code	Description
GC051	Replacement Cartridge
C0110	Adaptor - threeway thread for Diverter Valve
C0131	Hiflow Diverter Valve, Chrome Plated Brass, ever style
KTU4/LPW	Tubing per metre (soft - low pressure)
C0150	Spout Outlet (suits CT Series only)
C0160	Outlet Adaptor
C0170	Tubing Connector (connects tube to the unit)

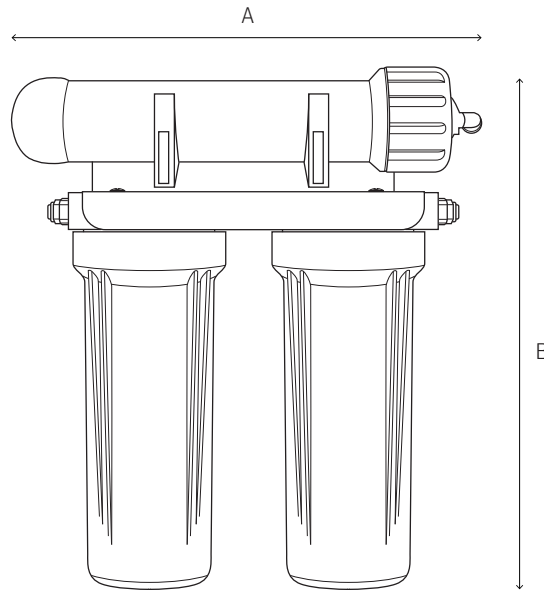

PRO270

A	B	Depth
355 mm	380 mm	140 mm

GENERAL INFO

PORTABLE REVERSE OSMOSIS FILTER SYSTEM

Puretec PRO270 Reverse Osmosis systems are very versatile with the garden tap connection supplied. The systems can be simply transferred for all its different applications. They are highly effective in removal of 98% of suspended particles, sediment, salt, bacteria, chemicals, cysts pesticides, heavy metals, chlorine, taste and odour with optional post filter kit.

SPECIFICATIONS

Model Number	PRO270
Maximum Flow	270 litres per day
Micron Rating	0.0005 micron ultra fine reverse osmosis membrane filtration
Replacement Cartridges And Accessories:	
Sediment Removal	PX051
Taste & Odour Removal	CB951
Reverse Osmosis Membrane	RET1812-75
Min/Max Temperature	0 - 30°C
Min/Max Pressure	300 - 875 kPa
Maximum Inlet TDS	2,000 mg/L
Maximum Hardness	171 mg/L - (10 grain)
Warranty	3 years^

Includes filter membrane, filter cartridges and spanner wrench.

FEATURES & BENEFITS

- Portable for using in different positions
- Connects easily to garden tap
- Complete with wall mounting bracket
- 0.0005 micron ultrafine reverse osmosis membrane filtration

KIT INCLUDES

- Garden Tap Connector
- Membrane
- cartridges
- Spanner wrench
- Valve

ADDITIONAL INFORMATION

The latest in Reverse Osmosis, a filtration process for high purity water. The ultra fine membrane operates by rejecting impurities and flushing them out to drain. This effectively eliminates 98% of all dissolved impurities, heavy metals, salts, viruses, bacteria, cysts, fluoride & chloride, chlorine, taste, odour, and chemicals. Only pure, sparkling clear water from your own water supply is left for your health, safety and peace of mind.

Pure & Healthy Water

Eliminates 98% of all dissolved impurities, heavy metals, salts, viruses, bacteria, cysts, fluoride & chloride, chlorine, taste, odour, and chemicals from your water.

Longer Filter Life

The PRO270 incorporates Puretec's long life filter technology, so you can go longer between filter replacements, and comes with our 3 Year Platinum Protection Warranty^.